

# J HEAD

## TRACKLESS LOW CLEARANCE PIPE HEAD



1.5" [38mm] to 6.7" [170mm] Diameter Range



Remote Welding Capabilities



Track or Trackless Mounting



Low Radial Clearance



Portable & Light-Weight



Field Proven on Preheated Pipe



Full Function

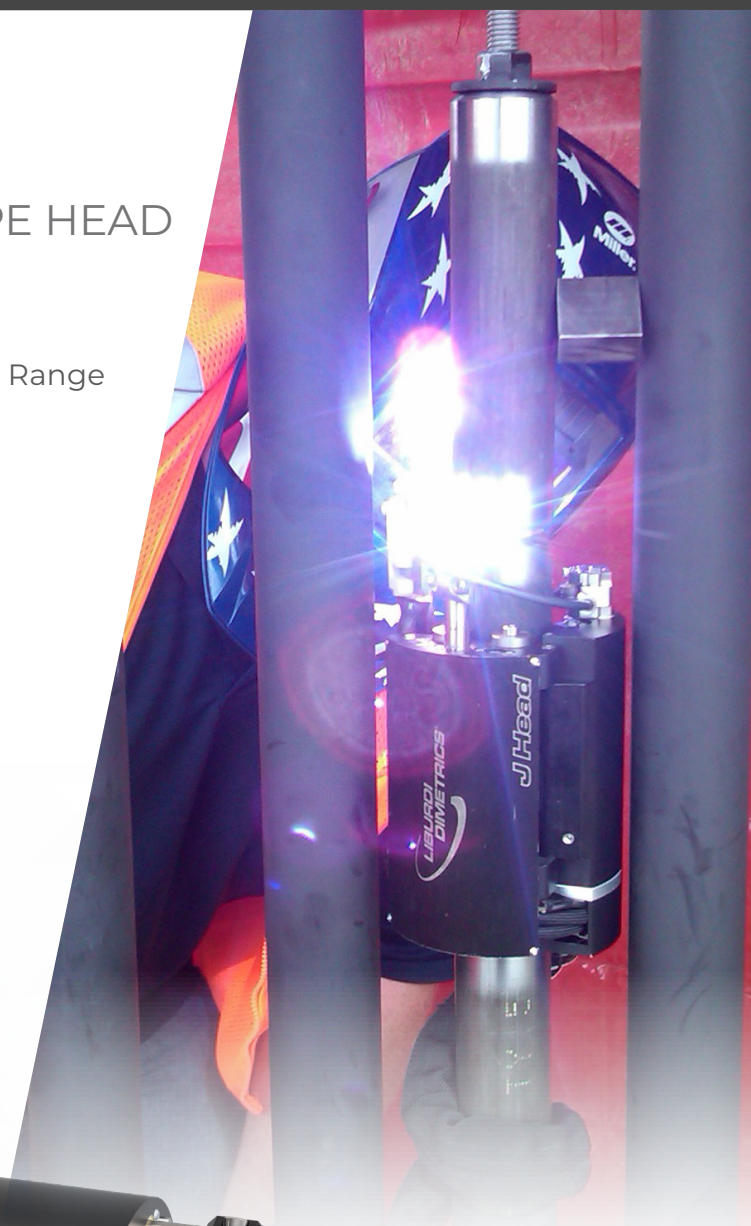
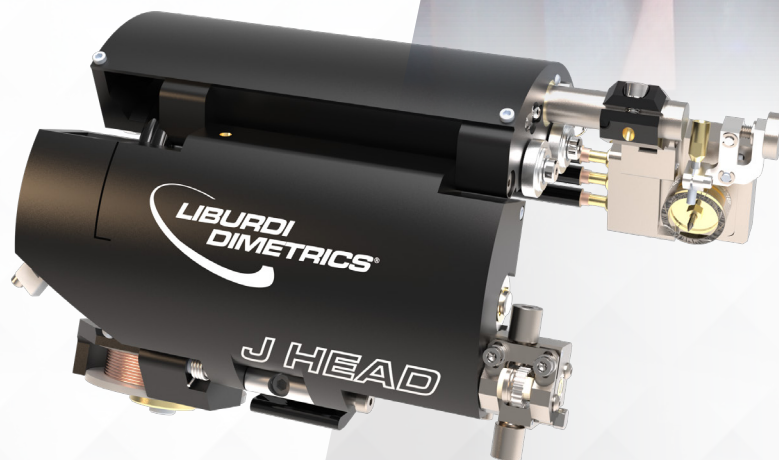

## ■ Specifications

- Radial Clearance: 1.5" [38 mm], 1.75" [44 mm] with track
- Axial Clearance:  
8.4" [213.4mm] with Oscillation fully retracted  
9.5" [241.3mm] with Oscillation fully extended
- AVC Axis Travel: 1.25" [32 mm]
- Oscillation/ Steering Travel: 0.70" [18 mm]
- Travel Axis Speed: 0.1 - 20 IPM
- Wire Feed Speed: 1 - 75 IPM
- Electrode: 0.093" [2.4 mm]
- Wire Size: 0.035" [0.8 mm]

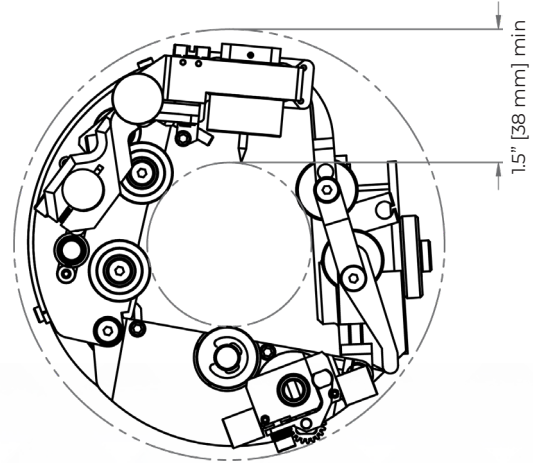

## ■ Standard Features

- Water cooled 200 Amp 100% duty cycle torch
- Servo controlled AVC, Travel, Wire Feed, and Oscillation
- Direct drive travel and top-loading electrode provide quick and easy set-up
- State-of-the-art gas delivery with clear shield cup for excellent arc visibility and gas coverage
- Adjustable lead/lag torch angle
- Horizontal and vertical adjustment wire entry
- Complete with carry case

## ■ Options

- Fillet weld attachments
- Leading and trailing cameras

